

HOBAS End Cap

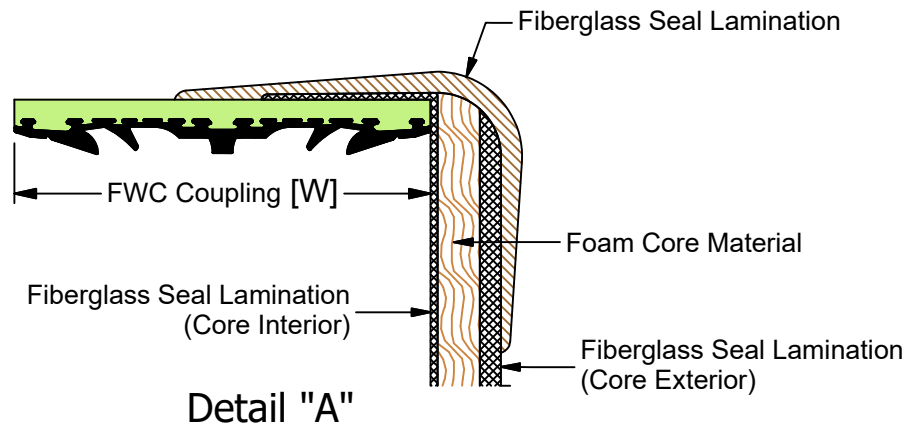
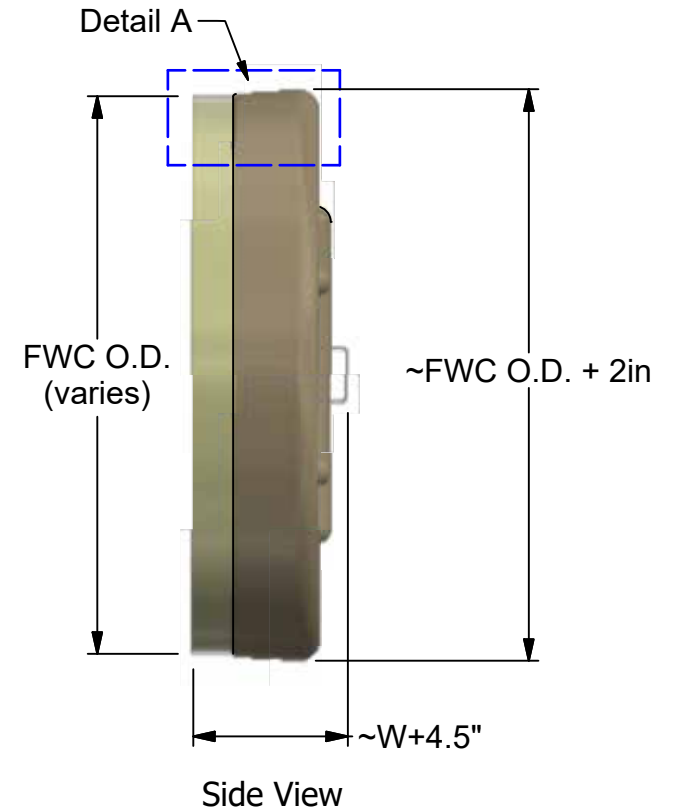
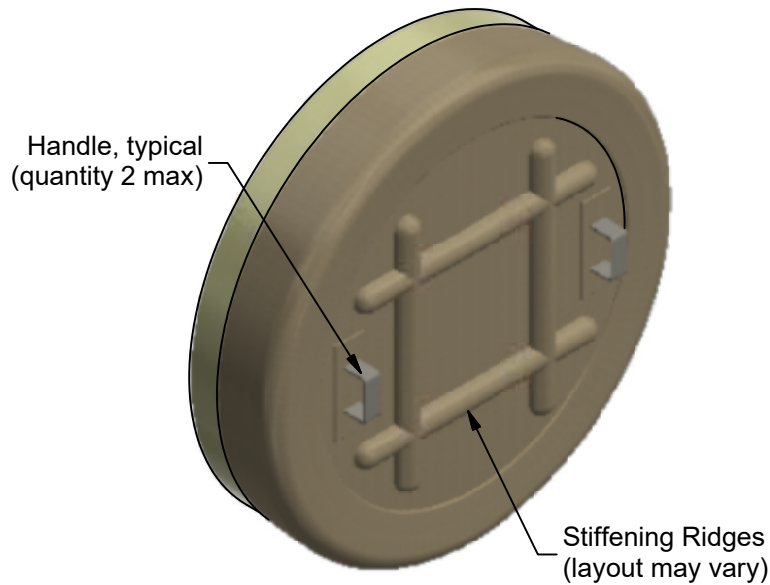

Notes:

1. See Appendix "C" of our [HOBAS Product Guide](#) for FWC weights and diameters.
2. Fiberglass end cover design is non-pressure rated and must be supported externally to withstand all working conditions.
2. End cap is design as a permanent closure when fully installed on the pipe.
3. All fabricated dimensions are +/- 0.25in.

FWC Width by Pipe Nominal Diameter		
(W)	Min Dia.	Max Dia.
~ 8.0"	18in	20in
~ 10.0"	24in	54in
~ 11.5"	57in	78in
~ 13.75"	84in	126in

HOBAS Pipe USA
 1413 E. Richey Road
 Houston, Texas 77073
 281-821-2200



www.hobaspipe.com

HOBAS®